

Liberty



IPEX6001U-WP-W & IPEX6002U-WP-W Install Guide



Product Features

IPEX6001U-WP-W

The IPEX6001U-WP-W is a 3 gang US wall plate SDVoE AVoIP encoder. The DigitalinXIP IPEX6001U-WP-W supports IP-based switching and extension of 4K/60Hz (4:4:4) video with zero frame latency up to 100 meters when using CAT6A F/UTP cabling. The encoder supports independent routing of all AV, USB 2.0, IR, Ethernet and RS232 signals over a 10Gbps network. AV inputs on the IPEX6001U-WP include HDMI and USB-C and the device will auto switch to whichever is connected last. IPEX6001U-WP-W has Icron USB2.0 High Speed host port (USB-B or C can be used as host) allowing USB signals to be routed to IPEX6002U-WP's or IPEX-USB2-C client devices. All encoders, decoders, and transceivers on an AV network can simultaneously transmit and receive full 4K 60 4:4:4 signals. The IPEX6001U-WP-W is HDMI 2.0 and HDCP 2.2 compliant and supports all video resolutions that fit into the HDMI 2.0 timing envelope of 594 MHz, such as 4K@60Hz 4:4:4 24bpp and 4K@60Hz 4:2:0 30bpp HDR, including DolbyVision, HDR10 and HLG. The encoder features light compression technology which is activated automatically when the raw data rate exceeds the 10Gbps Ethernet bandwidth so that all supported timing formats can be delivered through a single 10G Ethernet cable.

IPEX6001U-WP-W can be powered over the network via POE+ or by using the optional 24V power supply. Optional 24V power supply is required if USB-C device charging is desired.

The IPEX6001U-WP-W can be used in a point to point installation or in a matrix configuration that supports routing of one to one and one to many including multi-view for single display outputs and video wall configurations up to an 8x5 (Rows x Columns).

When multiple encoders, decoders, or transceivers are deployed in an AV network, an Arranger hardware controller is required for basic system access and operation.

Port speed requirements for each encoder range from 6-9Gbps for 4K signals and 3.2Gbps for 1080P signals, therefore the IPEX6001U-WP-W requires a 10GbE managed network switch for optimal performance, 1GbE managed network switches are not supported.

Package Contents

1. Installation Guide
2. IPEX6001U-WP-W
3. 3-pin Removable Phoenix Screw Terminal
4. IR Emitter

Product Features

IPEX6002U-WP-W

The IPEX6002U-WP-W is an AVoIP powered A/V decoder. The DigitalinXIP IPEX6002U-WP-W supports IP-based switching and extension of true 4K/60Hz (4:4:4) video with zero frame latency up to 100 meters when using CAT6A F/UTP cabling. The decoder supports independent routing of all AV, USB 2.0, IR, Ethernet and RS232 signals. IPEX6002U-WP-W has Icron USB2.0 High Speed client ports allowing USB signals to be routed to IPEX6001U-WP-W's or IPEX-USB2-H Host devices. All encoders, decoders, & transceivers on an AV network can simultaneously transmit and receive full 4K 60 4:4:4 signals. The IPEX6002U-WP-W is HDMI 2.0 and HDCP 2.2 compliant and supports all video resolutions that fit into the HDMI 2.0 timing envelope of 594 MHz, such as 4K@60Hz 4:4:4 24bpp and 4K@60Hz 4:2:0 30bpp HDR, including DolbyVision, HDR10 and HLG. The decoders features light compression technology which is activated automatically when the raw data rate exceeds the Ethernet bandwidth so that all supported timing formats can be delivered through a single 10G Ethernet cable.

IPEX6002U-WP-W can be powered over the network via POE+ or by using the optional 24V power supply.

The IPEX6002U-WP-W can be used in a point to point installation or in a matrix configuration that supports routing of one to one and one to many including multi-view for single display outputs and video wall configurations up to an 8x5 (Rows x Columns).

When multiple encoders, decoders, or transceivers are deployed in an AV network, an Arranger hardware controller is required for basic system access and operation.

Port speed requirements for each encoder is 6-9Gbps for 4K signals and 3.2Gbps for 1080P signals, therefore the IPEX6002U-WP-W requires a 10GbE managed network switch for optimal performance, 1GbE managed network switches are not supported.

Package Contents

1. Installation Guide
2. IPEX6002U-WP-W
3. 3-pin Removable Phoenix Screw Terminal
4. IR Receiver

Front and Rear Panels

IPEX6001U-WP-W Front Panel



1. Inputs : (USBC, HDMI)
2. 1gb LAN connection pass through
3. Source button select if in manual mode
4. LEDs:
 - USBC and HDMI show source active
 - Link; BLINKING; device is connected to switch and or another device. OFF; device is not connected to switch or another device
 - Power ; On device is power on. Off device power off.
5. Analog audio input/output
6. IR receiver in / IR emitter output
7. USB B Host Connection
8. RS232 / serial connection

IPEX60001U-WP-W Rear Panel



1. 10GBaseT AV Network connection with PoE+ support.
2. Power used to power device (if PoE+ is unavailable) and/or provide charging power for USB-C up to 65w. Optional power supply part number PS-24D-5V

Front and Rear Panels

IPEX6002U-WP-W Front Panel

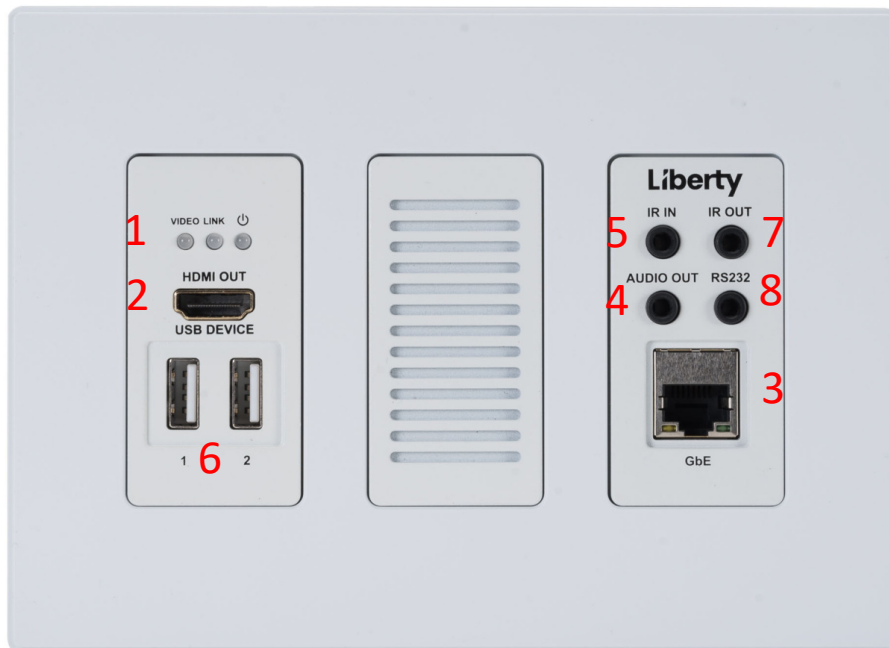

1. LEDs:
 - Video On; video is passing to display. No video is passing
 - Link; BLINKING; device is connected to switch and or another device. OFF; device is not connected to switch or another device
 - Power ; On device is power on. Off device power off.
2. HDMI connection for display / projector
3. 1gb LAN connection for pass through
4. Analog audio output
5. IR receiver in
6. USB A client / device Connection
7. IR emitter output
8. RS232 / serial connection

IPEX6002U-WP-W Rear Panel



1. 10GBaseT AV Network connection with PoE+ support.
2. Power used to power device (when PoE+ is unavailable). Optional power supply part number PS-24D-5V

System Installation Instructions

Connect IPEX6001U-WP-W, IPEX6002U-WP-W to Network Switch

Configure a 10GbE managed network switch for multicast video operation.

Note: A 1G network switch cannot be used with the 6000 series due to the high port speed requirements of the IPEX6001U-WP-W, IPEX6002U-WP-W a 10GbE managed network switch is required.

Liberty has documented several network switch settings for many common switch manufacturers, see documents related to this product on the product page of the Liberty AV website (www.libav.com).

Best Practice

When installing the AV endpoints, create a spreadsheet of all AVoIP transceivers notating the MAC address, the attached source/sync and the desired transceiver function, i.e. encoder, decoder or both. This will aid in fast final system commissioning that could be done remotely by accessing the AV system server via VPN or via port forwarding. See Arranger Documentation for more information on how to access the server and set up port forwarding.

Connect Arranger Controller

The provided Arranger hardware controller with the DigitalinXIP system should be hardwired via Ethernet to the AV network switch.

Arranger is an AVoIP server application that will configure and manage all transceiver components on an AV Network. Arranger is licensed per endpoint for one AV Network and a license unlock code should have been provided upon purchase of the Arranger DigiIP 6000 series license.

If you are missing the license unlock code contact supportlibav@libav.com and have serial number of the hardware controller nearby to confirm system license

Arranger Server Login

Once the hardware controller has been connected to the AV Network, the Arranger server application can be accessed via web browser on any PC that is connected to the same AV Network switch. By default the IP address for the Arranger server is 169.254.1.1. For initial system setup your PC will need to be in the same Network ID, i.e. 169.254/16.

Upon first login of the Arranger server you will be asked for an unlock code for your license, once the license has been entered you will be prompted for login credentials, by default the user name is *admin* and the password is *admin* to login to the system initially.

Once logged in you will be asked to change the admin login password.

Best Practice

Log the changed password that you created in your project documentation.

Once logged in you can configure, manage and control all signal types for the DigitalinXIP 6000 series transceivers. A complete operation manual and API for the Arranger system is located in the Arranger server application.

Connecting HDMI Devices

Use only high quality High Speed HDMI cables rated for 18Gbps, do not exceed HDMI cable lengths over 5m/15' for transceiver HDMI connections to AV sources and displays.

Connecting Audio Devices

The 3.5mm analog audio I/O connection can be configured as an input or an output and is configured in the Arranger server. Connect a 3.5mm stereo audio cable to the transceivers audio I/O port

Note: Audio output is 2 channel stereo audio only and is not capable of downmixing multi channel audio

Connecting USB Devices

A IPEX6001U-WP-W a USB host and IPEX6002U-WP-W is a client. Connect USB components with USB 2.0 rated cables, do not exceed cable lengths over 5m/15'

Note: IPEX6000TC-C supports USB 2.0 Full Speed signals up to 12Mbps, which is ideal for simple KVM or touch control. Do not use high quality USB microphones or webcams on the transceiver. IPEX6001U-WP-W and IPEX6002U-WP-W supports USB 2.0 High Speed signals up to 480Mbps.

Connecting IR Circuits

The IR connections on the transceivers provide a means to control remote IR equipment.

Note: Please ensure power is disconnected from the encoders and decoders before connecting the IR receiver to the IR input ports on the devices.

Connecting Serial / RS232 Compatible Devices

The RS232 connections on the transceivers provide a means to control 3rd party devices using serial commands. Connect the TX, RX, and ground control signal wires to the removable 3-pole terminal block, be sure the wiring from transceiver to the device is TX - RX, RX - TX, G - G. See illustration below

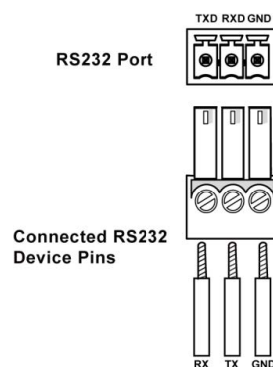

Application Diagrams

Point to Point AV Extender

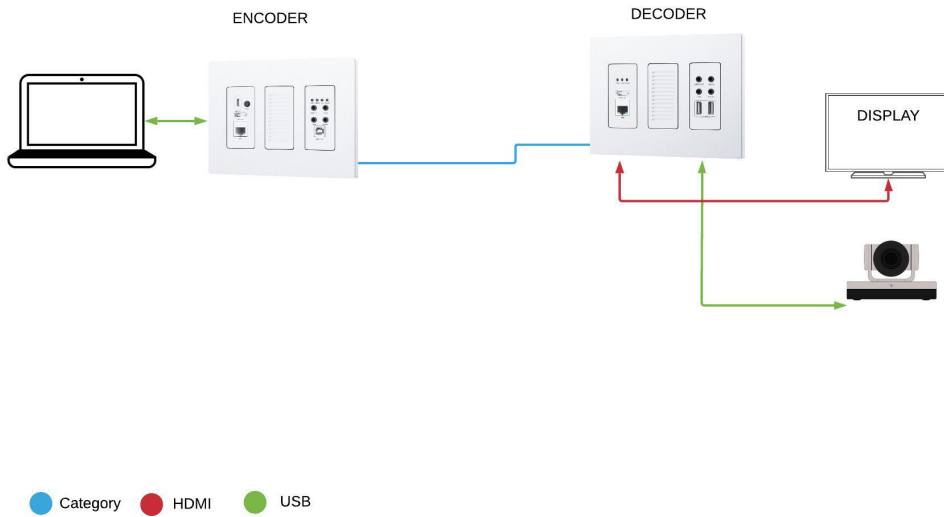

A/V Network Matrix

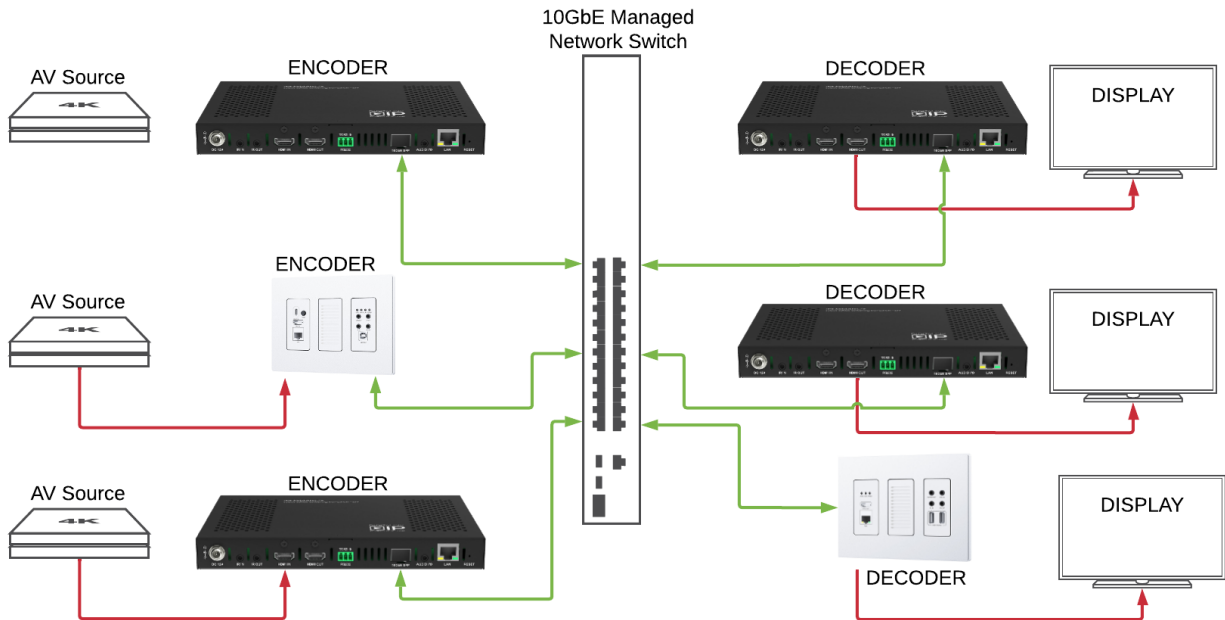

Note: Transceiver mode (encoder, decoder or both) can be configured by Arranger server

IPEX6001U-WP Technical Specifications

Input/Output Connections	
HDMI Input	One (1) HDMI Type A Receptacle
USBC Input	One (1) USBC
LAN	10GbE: One (1) 8P8C port (Shielded RJ45) LAN: One (1) 8P8C port (Shielded RJ45)
Power	One (1) 2 Pin 3.5mm phoenix connector
RS232 Port	One (1) 3.5 mm TRS Receptacle
USB Device	One (1) USB Type B Port
Audio Input / Output	One (1) 3.5 mm TRS Receptacle
IR Input	One (1) 3.5 mm TRS Receptacle
IR Output	One (1) 3.5 mm TRS Receptacle
Supported Audio, Video and Control	
Video Input Resolutions	Resolutions up to 4K@60Hz, 4:4:4 Supports HDR Metadata, including DolbyVision, HDR10 and HLG
Video Output Resolutions	Resolutions up to 4K@60Hz, 4:4:4 Supports HDR Metadata, including DolbyVision, HDR10 and HLG
Video Compliance	HDMI 2.0 and HDCP 2.2
Embedded Audio	HDMI: LPCM, 2.0/5.1/7.1 channel, 44.1/48/96/192 kHz, Dolby True HD, up to 7.1,192kHz, DTS-HD Master, up to 7.1,192kHz, Dolby Digital AC-3 (DVD format), DTS version 1 (DVD format) Analog / 3.5mm: Unbalanced 2 channel stereo
Supported Baud Rates	300, 600, 1200, 2400, 4800, 9600, 19200, 38400, 57600, 115200
USB Compliance	USB 2.0 High speed up to 480Mbps
Video Wall Scale Capability	Up to 8x5
Streaming Signal Characteristics	
Maximum Distance (point to point)	100m (984 ft) when using Cat6a/7
Maximum Distance (matrix, multi-view, video wall)	100m (984 ft) when using Cat 6a/7
Cable Requirements	Cat6a/7
Encoding Data Rate	4K Signals: Up to 8Gbps 1080p Signals: Up to 4Gbps
End to End Latency	Zero Frame Latency
Chassis and Environmental	
Dimensions (H x W x D)	105.6 mm x 140 mm x 47 mm (0.98in x 8.5 in x 5.5 in)
Weight	0.76kg / 1.67 lbs
Operating Temperature	0° to +45° C (+32° to +113° F)
Operating Humidity	10% to 90%, Non-condensing
Storage Temperature	-20° to +70° C (-4° to +140° F)
Storage Humidity	10% to 90%, Non-condensing
Power and Regulatory	
Power Input	24V DC 5A or 48V DC PoE+ (Power over Ethernet)
Power Consumption	10.1 watts
ESD Protection	8kV air, 4kV contact
Regulatory	FCC, CE, RoHS
Other	
Warranty	5 years
Included Accessories	Installation Guide, Wall plate plastic cover, 3-pin Removable Screw Terminal, IR emitter, IR receiver
Compatible Transceiver	IPEX6000TC-C, IPEX6000TC-F, IPEX6002U-WP-W

Distances and picture quality may be affected by cable grade, cable quality, source and destination equipment, RF and electrical interference, and cable patches.

IPEX6002U-WP Technical Specifications

Input/Output Connections	
HDMI output	One (1) HDMI Type A Receptacle
LAN	10GbE: One (1) 8P8C port (Shielded RJ45) LAN: One (1) 8P8C port (Shielded RJ45)
Power	One (1) 2 Pin 3.5mm phoenix connector
RS232 Port	One (1) 3.5 mm TRS Receptacle
USB Device	One (2) USB Type A female 01814548 Port
Audio Input / Output	One (1) 3.5 mm TRS Receptacle
IR Input	One (1) 3.5 mm TRS Receptacle
IR Output	One (1) 3.5 mm TRS Receptacle
Supported Audio, Video and Control	
Video Input Resolutions	Resolutions up to 4K@60Hz, 4:4:4 Supports HDR Metadata, including DolbyVision, HDR10 and HLG
Video Output Resolutions	Resolutions up to 4K@60Hz, 4:4:4 Supports HDR Metadata, including DolbyVision, HDR10 and HLG
Video Compliance	HDMI 2.0 and HDCP 2.2
Embedded Audio	HDMI: LPCM, 2.0/5.1/7.1 channel, 44.1/48/96/192 kHz, Dolby True HD, up to 7.1,192kHz, DTS-HD Master, up to 7.1,192kHz, Dolby Digital AC-3 (DVD format), DTS version 1 (DVD format) Analog / 3.5mm: Unbalanced 2 channel stereo
Supported Baud Rates	300, 600, 1200, 2400, 4800, 9600, 19200, 38400, 57600, 115200
USB Compliance	USB 2.0 High speed up to 480Mbps
Video Wall Scale Capability	Up to 8x5
Streaming Signal Characteristics	
Maximum Distance (point to point)	100m (984 ft) when using Cat6a/7
Maximum Distance (matrix, multi-view, video wall)	100m (984 ft) when using Cat 6a/7
Cable Requirements	Cat6a/7
Encoding Data Rate	4K Signals: Up to 8Gbps 1080p Signals: Up to 4Gbps
End to End Latency	Zero Frame Latency
Chassis and Environmental	
Dimensions (H x W x D)	105.6 mm x 140 mm x 47 mm (0.98in x 8.5 in x 5.5 in)
Weight	0.76kg / 1.67 lbs
Operating Temperature	0° to +45° C (+32° to +113° F)
Operating Humidity	10% to 90%, Non-condensing
Storage Temperature	-20° to +70° C (-4° to +140° F)
Storage Humidity	10% to 90%, Non-condensing
Power and Regulatory	
Power Input	24V DC 5A or 48V DC PoE+ (Power over Ethernet)
Power Consumption	10.1 watts
ESD Protection	8kV air, 4kV contact
Regulatory	FCC, CE, RoHS
Other	
Warranty	5 years
Included Accessories	Installation Guide, Wall plate plastic cover, 3-pin Removable Screw Terminal, IR emitter, IR receiver
Compatible Transceiver	IPEX6000TC-C, IPEX6000TC-F, IPEX6001U-WP-W

Distances and picture quality may be affected by cable grade, cable quality, source and destination equipment, RF and electrical interference, and cable patches.

Thank you for your purchase.

For Technical Support please call our toll free number at
800-530-8998 or email us at supportlibav@libav.com

www.libav.com

The logo for Liberty, featuring the word "Liberty" in a bold, black, sans-serif font. The letter "i" is stylized with a small orange square above it.

1490 Garden of the Gods Suite F
Colorado Springs, Colorado
80907 USA
Phone: 719-260-0061
Fax: 719-260-0075
Toll-Free: 800-530-8998